

UNIT 3 – Molecular Biology Techniques

Southern Blotting

I. History and Definition –

- Developed by Dr. Edwin Southern in 1975
- **Def** – A molecular biology technique used to detect specific DNA sequences by transferring DNA fragments from an agarose gel to a membrane, such as a nitrocellulose or nylon membrane, followed by hybridization with a labelled probe and detection of the bound probe.

II. Components –

Component	Role / Importance
DNA Sample	<ul style="list-style-type: none"> • Starting material to be analyzed • Quality and quantity of sample critical – for achieving good separation and accurate results
Restriction Enzymes	<ul style="list-style-type: none"> • Used to cut the DNA sample into smaller fragments • Choice of restriction enzymes depends on the specific DNA sequence being targeted.
Agarose Gel = agarose + buffer solution	<ul style="list-style-type: none"> • Used to separate the DNA fragments based on their size through electrophoresis • Agarose = polysaccharide derived from red algae
Buffer solution	TAE or TBE
Loading dye	Bromophenol blue
Tracking dye	EtBr (Ethidium bromide)
Nitrocellulose membrane (Transfer membrane)	<ul style="list-style-type: none"> • Used to immobilize and retain DNA fragments after transfer from an agarose gel • Compatible with various detection methods, including radioactive and non-radioactive probes
Probe	<ul style="list-style-type: none"> • A labelled probe, usually a radioactive or fluorescent molecule → designed to bind specifically to the target DNA sequence → probe prepared by labelling a DNA fragment with the desired molecule. • Example – Radioactive probe ^{32}P (emits β particles that can be detected by autoradiography).
Washing buffer	<ul style="list-style-type: none"> • Used to remove excess / unbound probe
Autoradiography	<ul style="list-style-type: none"> • Used to visualize the bound probe on the membrane by exposing the membrane to X-ray film, which captures the radioactive signal from the bound probe

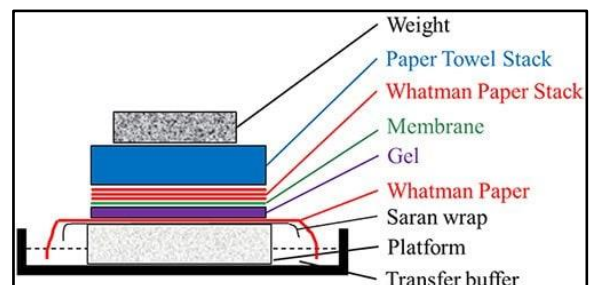
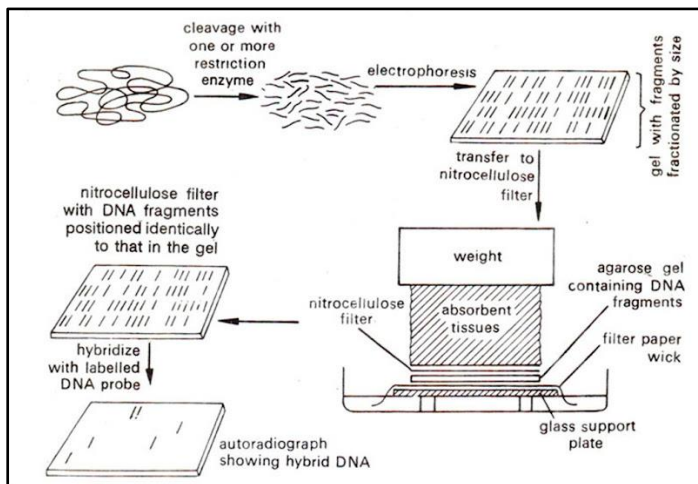

III. Steps of Southern Blotting –

Step 1: Electrophoresis

1. **DNA Sample Preparation** – DNA sample (to be analyzed) → first cut into smaller fragments using restriction enzymes through restriction digestion → fragments then mixed with a buffer solution and a tracking dye.
2. **Agarose Gel Preparation** – ~0.7% agarose gel prepared by melting agarose in a buffer solution + cooling it to form a solid gel → gel is then placed in an electrophoresis chamber.
3. **Electrophoresis** – DNA fragments loaded onto the agarose gel → electric field applied → fragments separate based on their size due to their different migration rates through the gel → Smaller fragments move faster ; larger fragments move slower.



Step 2: Transfer

Separated DNA fragments → transferred from the agarose gel to the transfer membrane (nitrocellulose or nylon) using a process called capillary transfer or vacuum blotting.

Crucial step for ensuring – the DNA fragments are accurately transferred + the membrane is free of any residual agarose.



Step 3: Hybridization

Labelled probe is added to the membrane → binds to the target DNA sequence → typically takes several hours to overnight.

Critical factors – hybridization conditions, including temperature, time, and buffer composition



Step 4: Washing

Unbound probe is washed away → to minimize background signal

Crucial step for ensuring – the signal detected is specific to the target DNA sequence.



Step 5: Detection

The bound probe is detected using a suitable detection method. The detection method used depends on the type of label used on the probe.

- (a) **Autoradiography** – used for radioactive probes
- (b) **Fluorescence microscopy** – used for fluorescent probes.

IV. Applications of Southern Blotting –

1. **DNA Sequence Analysis** – used to analyze and identify specific DNA sequences, such as gene expression patterns or genetic variations.
2. **Genetic Engineering** – used to detect and verify the presence of specific DNA sequences in genetically engineered organisms.
3. **Genetic Diagnosis** – used to detect genetic mutations or variations associated with genetic disorders.
4. **Basic Research** – used to study gene regulation, gene expression, and genetic variation in various organisms.

V. Key factors of Southern Blotting that influence the accuracy and reliability of the results –

1. DNA sample quality
2. Probe specificity
3. Hybridization conditions
4. Detection method

Western Blotting

Northern Blotting

Difference between Southern, Western and Northern Blotting

**SOUTHERN VS NORTHERN VS
WESTERN BLOTTING**

A procedure for identifying specific sequences of DNA	A procedure used to detect specific sequences of RNA by hybridization with complementary DNA	A blotting procedure used to identify specific amino-acid sequences in proteins
Developed by Edward M. Southern in 1975	Developed by Alwine and colleagues in 1979	Developed by George Stark's group at Stanford University in 1979
Detects specific DNA sequence	Detects specific RNA sequences	Detects specific proteins
Involves Agarose gel electrophoresis	Involves denaturing formaldehyde agarose gel	Involves SDS PAGE
Involves capillary transfer	Involves capillary transfer	Involves electric transfer
Uses DNA probes	Uses cDNA probes	Uses primary and secondary antibodies
Used to identify specific gene sequences and in DNA fingerprinting	Used in gene expression analysis	Used in disease diagnosis Visit www.pediaa.com

Ⓟ Detection by Autoradiography, Chemiluminescent, colorimetric	Autoradiography, Chemiluminescent, colorimetric	Chemiluminescent, colorimetric.
--	---	---------------------------------

Microarray

I. History and Definition –

- Invented by Patrick O. Brown
- **Def** – a molecular biology technique used to study thousands of nucleic acid fragments simultaneously
- Involves the hybridization of labelled samples (probes) to immobilized nucleic acid sequences (targets) on a glass slide.

II. Components –

Component	Role / Importance
mRNA Sample	<ul style="list-style-type: none">• Extracted from cells and is used to bind to the probes on the microarray.• mRNA molecules are labelled with fluorescent dyes to facilitate detection.
Microarray Chip	<ul style="list-style-type: none">• The surface where the probes are attached• Made of glass or silicon and is coated with a thin layer of chemicals to facilitate the binding of probes and mRNA molecules.
Probes	<ul style="list-style-type: none">• Short DNA sequences that are designed to bind to specific mRNA molecules.• Attached to the microarray chip and are used to detect the expression levels of genes.
Fluorescent Dyes	<ul style="list-style-type: none">• Used to label the mRNA molecules.• Emit light when excited by a laser, allowing researchers to detect the bound mRNA molecules.
Scanning Instrument	<ul style="list-style-type: none">• Used to detect the bound mRNA molecules.• Excites the fluorescent dyes with a laser and measures the emitted light to determine the expression levels of genes.

III. Steps of Microarray Analysis –

Step 1: Sample Isolation and Preparation

1. **Sample Isolation** – Extract control and target mRNA from biological samples.
Example, a non-cancerous cell line versus a cancerous cell line.
2. **RNA Conversion** – Convert the extracted RNA into complementary DNA (cDNA) – **Reverse transcription**.
3. **Labelling** – Label the cDNA with a fluorescent dye, typically Cy3 (red) for the target and Cy5 (green) for the control.



Step 2: Hybridization

1. **Array Preparation** – The microarray slide is prepared by immobilizing nucleic acid sequences (probes) on the surface.
2. **Hybridization** – The labelled cDNA samples are hybridized to the probes on the array. The DNA will strongly or weakly hybridize, or not at all.



Step 3: Washing

The array slide is washed with buffer to remove any DNA that did not strongly hybridize to a probe. This helps prevent cross-hybridization and ensures specific binding.



Step 4: Analysis

1. **Image Acquisition** – The array slide is exposed to laser excitation, and the fluorescent emission is measured using a confocal microscope.
2. **Image Processing** – The acquired image is processed to extract intensity values for each spot. This includes –
Gridding + Segmentation (spot picking) + Data extraction.



Step 5: Data Analysis

1. **Data Filtering** – The extracted intensity values are filtered to remove spots with low, high, or negative intensity values, which can be associated with high variance or background noise.
2. **Data Analysis Methods** – Various methods are used to analyze the filtered data, such as –
 - (a) Hierarchical clustering
 - (b) K-means clustering
 - (c) Self-organizing feature maps
 - (d) Support vector machines
 - (e) Neural networks
 - (f) Principle Component Analysis.
3. **Data Mining and Enrichment** – The analyzed data is used to identify patterns of gene expression, co-regulated groups of genes, and regulatory cascades.

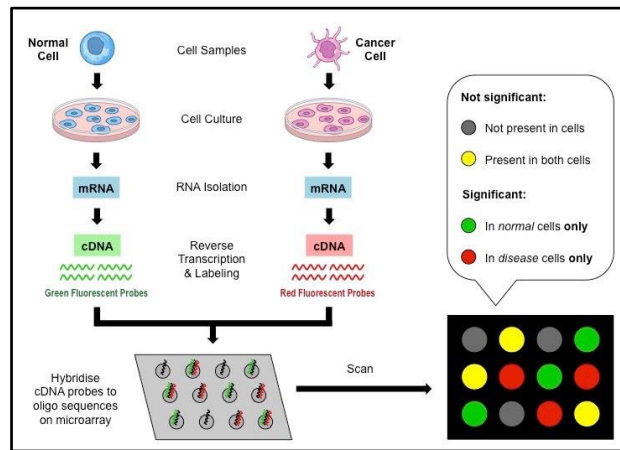

IV. Applications of Microarray –

1. **Gene Expression Analysis** – Studying the expression levels of thousands of genes simultaneously, allowing researchers to identify genes that are differentially expressed in different conditions, and analyzing genomic variations, such as copy number changes or single nucleotide polymorphisms (SNPs).
2. **Epigenetic Analysis** – Studying epigenetic modifications, such as DNA methylation or histone modifications.
3. **Disease Diagnosis** – Used to diagnose diseases by identifying specific gene expression patterns associated with certain conditions.
4. **Gene Regulation Studies** – Used to study the regulation of gene expression, including the effects of transcription factors and other regulatory elements.
5. **Pharmacogenomics** – Used to study the effects of drugs on gene expression, allowing researchers to identify potential side effects and optimize treatment regimens.

V. Key factors of Microarray involved –

1. **Probe Design** – Probes must be specific to the target mRNA molecules and must not cross-hybridize with other mRNA molecules.
2. **Sample Quality** – Samples must be free of contaminants and must be properly labelled with fluorescent dyes.
3. **Array Design** – The design of the array, including the choice of nucleic acid sequences and their density, is critical for optimal performance.
4. **Hybridization Conditions** – The conditions under which the probes are hybridized to the array, such as temperature, time, and concentration of reagents, can significantly impact the results.
5. **Data Analysis** – The analysis of microarray data is complex and requires specialized software and expertise.
6. **Data Standards** – Adherence to data standards, such as **MIAME (Minimum Information About a Microarray Experiment)**, is essential for ensuring the reproducibility and comparability of microarray data.

Flow Cytometry

I. History and Definition –

- Developed in the 1960s by Dr. Gey and Dr. Ginsberg
- **Def** – A molecular biology technique used to detect and measure the physical and chemical characteristics of a population of cells or particles.
- **FLOW = fluid in which the cells are suspended + CYTOMETRY = measurement of cells**
- Involves suspending cells in a fluid and passing them through a laser beam, where each cell is analyzed for various properties such as size, granularity, DNA content, and surface receptors.
- **Architecture of FACSCalibur –**
 - ✓ **Dual-Laser Design** – Uses two lasers, an air-cooled argon laser and a red diode laser, for high sensitivity and flexibility in fluorochrome selection.
 - ✓ **Supports Multicolor Analysis** – The instrument supports multicolor analysis with up to four colors, allowing for the detection of multiple cell populations and biomarkers.
 - ✓ **Modular Design** – designed to be easily upgraded and modified to meet evolving research and clinical needs.
 - ✓ **User-Friendly Interface** and intuitive software solutions **to streamline analysis** and data acquisition.

II. Components –

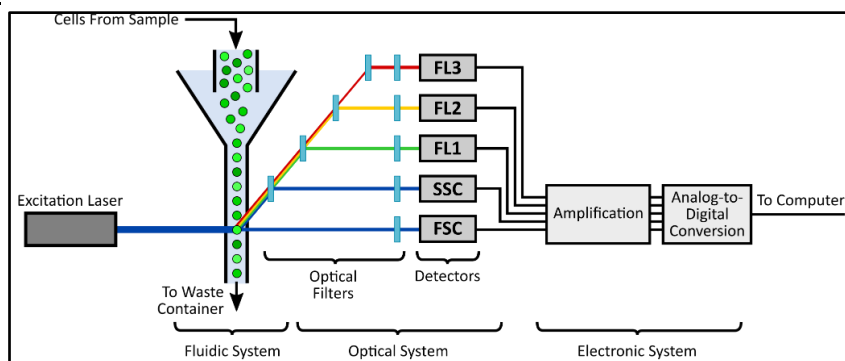

III. Principle of FSC and SSC –

Forward scatter (FSC) and side scatter (SSC) = two key parameters used to analyze the physical characteristics of cells or particles → measured by detecting the light scattered by the particles as they pass through a laser beam.

Parameter	What it measures	Proportional to	Used to
Forward Scatter (FSC)	Measures the light scattered by the particles in the direction of the laser beam.	FSC \propto Size of the particles ∴ Larger particles scatter more light in the forward direction, resulting in a higher FSC signal.	Used to gate out debris and to identify larger particles such as cells.
Side Scatter (SSC)	Measures the light scattered by the particles at a 90° angle to the laser beam.	SSC \propto Granularity or Complexity of the particles ∴ Particles with more internal complexity, such as those with a higher number of organelles or proteins, scatter more light at a 90° angle, resulting in a higher SSC signal.	Used to identify particles with different levels of granularity or complexity.

Interpretation of FSC and SSC

When plotted together on a two-dimensional scatter plot, FSC and SSC can be used to identify different cell populations based on their size and granularity.

For example –

Particle / Cell	Size	FSC Signal	SSC Signal
Debris (particle)	Small	low	low
Lymphocytes	Small	low	low
Monocytes	Medium-sized	medium	low
Granulocytes	Large	high	high

IV. Steps of Flow Cytometry –

Step 1: Sample Preparation

1. **Cell Suspension** – Cells are suspended in a fluid, typically a buffered saline solution.
2. **Labelling** – Cells are labelled with fluorescent markers or other reagents to enhance detection.
Fluorochrome labelling in flow cytometry involves attaching fluorescent molecules, known as fluorochromes, to specific targets such as proteins, nucleic acids, or other biomarkers.
 - (a) **Directly Labelled Fluorochromes** – fluorescein isothiocyanate (FITC) and propidium iodide (PI)
 - (b) **Tandem Dyes** – first dye (donor) is excited, and it transfers energy to the second dye (acceptor), which then fluoresces.
 - (c) **Quantum Dots** - fluorescent nanocrystals that can be excited by a range of wavelengths and emit light at different wavelengths depending on their size.



Step 2: Instrumentation

Component	Role / Importance	Principle
Fluidics System	<ul style="list-style-type: none">• Responsible for transporting the sample from the sample tube to the flow cell, past the laser, and sorted or discarded	<ol style="list-style-type: none">1. Sheath Fluid – fluid carries and aligns the cells so that they pass single file through the light beam for sensing2. Hydrodynamic Focusing – used to maintain the central fluid stream / laminar flow
Optics	<ul style="list-style-type: none">• Includes excitation light sources, lenses, and optical filters used to collect and move wavelengths of light around the instrument.• The detection system generates photocurrent, which helps analyze cell type.	<ol style="list-style-type: none">1. Excitation Light Sources – provide the light that interacts with the cells, such as lasers or lamps.2. Lenses and Filters – ensure correct wavelengths are detected
Electronics	<ul style="list-style-type: none">• Controls the flow of the sample, laser power, and data acquisition.• Processes the data and displays it in a histogram or dot plot.	<ol style="list-style-type: none">1. Amplification System – linear or logarithmic, used for amplifying the photocurrent to improve signal-to-noise ratios.2. Analog-to-Digital Conversion (ADC) – converts the analog measurements of forward-scattered light (FSC), side-scattered light (SSC), and fluorescence signals into digital signals that can be processed by a computer



Step 3: Data Acquisition

1. **Measurement** – The instrument measures the physical and chemical properties of the cells, such as size, granularity, and fluorescence.
2. **Data Processing** – The data is processed by a computer using specialized software.



Step 4: Data Analysis – Gating

The data is plotted in a single dimension, two-dimensional dot plots, or three-dimensional plots, and regions are defined based on fluorescence intensity.

V. Applications of Flow Cytometry –

1. **Immunophenotyping** – Identifying and quantifying specific cell populations based on surface markers and intracellular proteins.
2. **Cell Sorting** – Separating specific cell populations from a heterogeneous sample for further analysis or downstream applications
3. **Cell Cycle Analysis** – Analyzing cell cycle phases and cell proliferation, including apoptosis and cell death mechanisms.
4. **Cell Proliferation Assays** – Measuring cellular metabolic activity and proliferation in response to specific stimuli.
5. **Serological Testing** – Detecting and quantifying antibodies in serum samples, including multiple antibodies at once
6. **Apoptosis** – Studying mechanisms of cell death and differentiating between necrosis and early apoptosis.
7. **Drug Development** – Utilizing flow cytometry in drug development research, including identifying potential therapeutic targets and monitoring drug efficacy.

Capillary Electrophoresis

Capillary electrophoresis (CE) is an analytical technique that separates charged molecules based on their electrophoretic mobility under an applied voltage. It uses narrow bore capillaries to separate ions in a capillary based on their charge and size. The technique involves the differential movement of ions under an electric field based on their charge and size, allowing for high efficiency, short analysis times, and low sample volume requirements.

History and Definition

developed in the 1980s by James W. Jorgensen and Krynn DeArman Lukacs, who demonstrated its capabilities in separating complex mixtures.

Components and Their Role/Importance

Components	Role
Sample Vial	Contains the sample to be analyzed.
Source and Destination Vials	Filled with an electrolyte solution, these vials provide the electric field for the separation process.
Capillary	A narrow bore tube (typically 20-200 μm in diameter) where the separation takes place.
Electrodes	Apply the electric field to the capillary.
High-Voltage Power Supply	Provides the electric field.
Detector	Measures the separated compounds.
Data Output and Handling Device	Displays the results as an electropherogram.

Steps

Step 1 – Sample Introduction

The capillary inlet is placed into a vial containing the sample, which is introduced into the capillary via capillary action, pressure, siphoning, or electrokinetically.



Step 2 – Electric Field Application

The high-voltage power supply applies an electric field between the source and destination vials.



Step 3 – Separation

The analytes migrate through the capillary based on their electrophoretic mobility, with ions moving towards the electrodes.



Step 4 – Detection

The separated compounds are detected near the outlet end of the capillary.



Step 5 – Data Analysis

The output of the detector is sent to a data output and handling device, which displays the results as an electropherogram.

Modes of Capillary Electrophoresis

- 1. Capillary Zone Electrophoresis (CZE):** The most commonly used technique, which separates ions based on their electrophoretic mobility.
- 2. Capillary Gel Electrophoresis (CGE):** Uses a gel to separate particles based on their size.
- 3. Micellar Electrokinetic Capillary Chromatography (MEKC):** Uses a micelle to separate particles based on their partitioning into the micelle.

Applications

1. **Pharmaceutical Analysis:** For the analysis of pharmaceutical compounds and their impurities.
2. **Protein Analysis:** For the separation and identification of proteins.
3. **Nucleic Acid Analysis:** For the separation and identification of nucleic acids.
4. **Enantiomer Analysis:** For the separation of enantiomers.
5. **Microbial Contamination Detection:** For the detection of microbial contamination in food and water samples.

Advantages

1. **High Efficiency:** High resolution and speed of separation.
2. **Short Analysis Times:** Fast analysis times, often under 10 minutes.
3. **Low Sample Volume Requirements:** Requires only a few nanoliters of sample.
4. **Automation:** Critical for precise quantitative analysis.

Disadvantages

1. **Sensitivity Issues:** Requires careful control of experimental conditions to achieve high sensitivity.
2. **Lack of Standardized Methods:** Different methods and conditions can affect the results, making standardization challenging.

Overall, capillary electrophoresis is a powerful analytical technique that offers high efficiency, speed, and sensitivity for the separation and analysis of charged molecules.

PCR

The polymerase chain reaction (PCR) is a widely used molecular biology technique to amplify specific DNA sequences. It was developed in 1983 by Kary Mullis, an American biochemist, and has revolutionized the field of molecular biology by enabling the rapid and accurate amplification of DNA samples.

Definition and History

PCR is a method used to make millions to billions of copies of a specific DNA sample rapidly, allowing scientists to study and analyze very small samples of DNA. It was invented by Kary Mullis at Cetus Corporation and has since become a crucial tool in various fields, including genetics, forensic analysis, and medical diagnostics.

Components and Their Role/Importance

Components	Role
DNA Template	The DNA of interest from the sample, which contains the region to be copied.
DNA Polymerase	An enzyme that polymerizes new DNA strands. Taq polymerase is commonly used due to its thermostability.
Oligonucleotide Primers	Short stretches of single-stranded DNA complementary to the 3' ends of sense and anti-sense strands. These primers define the target sequence and serve as the starting point for DNA synthesis.
Deoxyribonucleotide Triphosphates (dNTPs)	The building blocks for DNA synthesis, providing energy for polymerization.
Buffer System	Magnesium and potassium ions provide optimum conditions for DNA denaturation and renaturation, ensuring fidelity, polymerase activity, and stability.

Steps

The PCR process involves three major cyclic reactions:

- 1. Denaturation:** The reaction mixture is heated to 94°C for about 0.5 to 2 minutes, breaking the hydrogen bonds between the two strands of DNA and converting it into single-stranded DNA.
- 2. Annealing:** The temperature is reduced to about 55°C, allowing the primers to bind to the template at their complementary sites.
- 3. Extension:** The temperature is raised to about 72°C, and the DNA polymerase begins adding nucleotides onto the ends of the annealed primers.

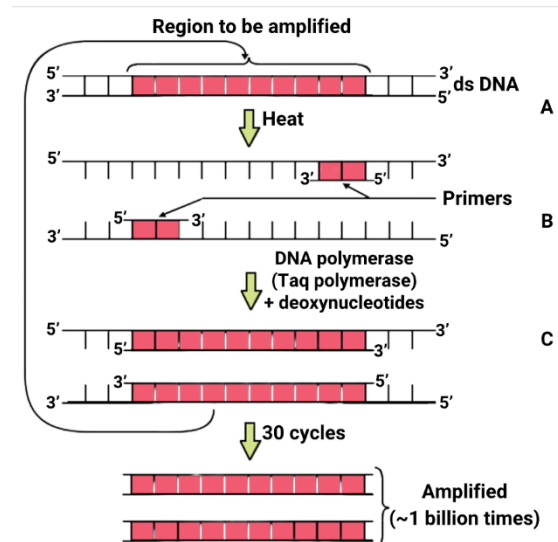

Applications

- 1. Forensic Science:** PCR is used to analyze minute traces of blood and other tissues to identify the donor by their genetic "fingerprint."
- 2. Genetic Testing:** PCR is used to diagnose genetic diseases and detect low levels of viral infection.
- 3. Evolutionary Biology:** PCR is used to amplify DNA fragments found in preserved tissues, such as those of ancient organisms.
- 4. Medical Diagnostics:** PCR is used to detect genetic mutations and diagnose diseases.
- 5. Biotechnology:** PCR is used in genetic engineering and gene cloning.

In summary, PCR is a powerful tool that enables the rapid and accurate amplification of specific DNA sequences. Its components and steps work together to generate millions of copies of a DNA sample, making it a crucial technique in various fields of molecular biology and biotechnology.

RT – PCR

Definition and History

Real-time polymerase chain reaction (real-time PCR) is a variation of the standard PCR technique that allows for the real-time monitoring of the PCR progress. It was developed in the 1990s and has since become a widely used tool for detecting and quantifying specific DNA or RNA sequences. Real-time PCR is a modification of the conventional PCR technique, enabling real-time monitoring of the PCR progress. This technique has revolutionized the detection and quantification of target nucleic acids, offering great sensitivity and specificity, and has been widely applied in various research areas.

Components and Their Role/Importance

Components	Role
DNA Template	The DNA of interest from the sample, which contains the region to be copied.
DNA Polymerase	An enzyme that polymerizes new DNA strands. Taq polymerase is commonly used due to its thermostability.
Oligonucleotide Primers	Short stretches of single-stranded DNA complementary to the 3' ends of sense and anti-sense strands. These primers define the target sequence and serve as the starting point for DNA synthesis.
Deoxyribonucleotide Triphosphates (dNTPs)	The building blocks for DNA synthesis, providing energy for polymerization.
Buffer System	Magnesium and potassium ions provide optimum conditions for DNA denaturation and renaturation, ensuring fidelity, polymerase activity, and stability.
Reporter Dyes	Fluorescent dyes used to detect the amplified product during the PCR process.
Passive Reference Dyes	Dyes used to normalize the fluorescence signal and correct for variations in the instrument's sensitivity.

Steps

Reverse Transcription (RT):

This step involves converting RNA into complementary DNA (cDNA) using reverse transcriptase. The cDNA is then used as the template for PCR.



PCR Amplification:

- Denaturation:** The reaction mixture is heated to 94°C for about 0.5 to 2 minutes, breaking the hydrogen bonds between the two strands of DNA and converting it into single-stranded DNA.
- Annealing:** The temperature is reduced to about 55°C, allowing the primers to bind to the template at their complementary sites.
- Extension:** The temperature is raised to about 72°C, and the DNA polymerase begins adding nucleotides onto the ends of the annealed primers.



Real-Time Monitoring:

The PCR process is monitored in real-time using fluorescent reporter dyes that bind to the amplified DNA. The fluorescence is measured by the real-time PCR instrument, allowing for the quantification of the target DNA/RNA.



Data Analysis:

The real-time PCR data is analyzed by plotting the fluorescence against the cycle number. The threshold cycle (C_t) or quantification cycle (C_q) is determined by setting a threshold for detection of DNA-based fluorescence. The C_t value is inversely proportional to the initial amount of target DNA/RNA, allowing for precise quantification.

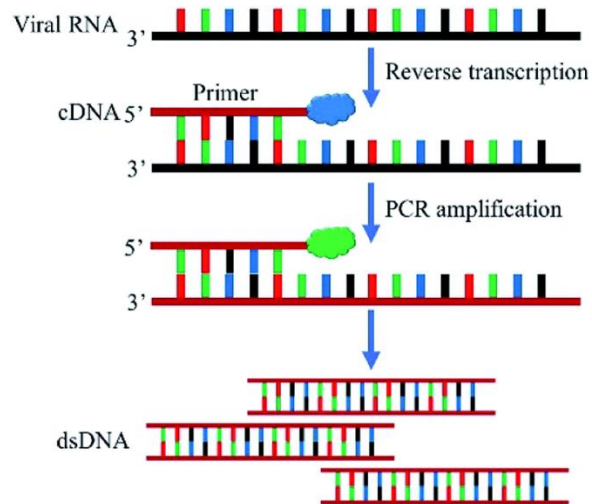

Applications

1. **Forensic Science:** Real-time PCR is used to analyze minute traces of blood and other tissues to identify the donor by their genetic "fingerprint."
2. **Genetic Testing:** Real-time PCR is used to diagnose genetic diseases and detect low levels of viral infection.
3. **Evolutionary Biology:** Real-time PCR is used to amplify DNA fragments found in preserved tissues, such as those of ancient organisms.
4. **Medical Diagnostics:** Real-time PCR is used to detect genetic mutations and diagnose diseases.
5. **Biotechnology:** Real-time PCR is used in genetic engineering and gene cloning.
6. **Cancer Diagnosis:** Real-time PCR is used to detect and quantify specific genetic markers associated with cancer.
7. **Viral Load Determination:** Real-time PCR is used to determine the viral load of a clinical specimen, which is critical for monitoring disease progression and treatment efficacy.

In summary, real-time PCR is a powerful tool that enables the real-time monitoring of PCR progress, allowing for precise detection and quantification of specific DNA or RNA sequences. Its components and steps work together to generate accurate results, making it a crucial technique in various fields of molecular biology and biotechnology.

PCR VERSUS RT-PCR

PCR is a technique to amplify a segment of DNA, generating millions of copies of a DNA sequence

RT-PCR is a variant of PCR used in the detection of gene expression in molecule biology

Denaturation, annealing, and extension are the three steps

Reverse transcription is followed by PCR

A double-stranded DNA molecule serves as the template

A single-stranded RNA molecule is the template for the reverse transcription; a single-strand DNA molecule is the template for the PCR

DNA polymerase is used as the enzyme

Reverse transcriptase and DNA polymerase are used as enzymes

Forward and reverse primers are used

Reverse primer is used for reverse transcription

Comparatively less sensitive

More sensitive method

Used in functional analysis of genes, diagnosis, and monitoring of hereditary diseases, DNA cloning, DNA sequencing, and ancient DNA amplification

Used in the detection of gene expression

Visit www.pediaa.com